

## Electrical Specifications

Supply Input .....	9V to 30V 1.0A <i>Examples:</i> Digikey part 271-1112 or Digikey part Z1158
Dimensions .....	0.96" x 1.4" x 0.6" (24mm x 35mm x 15.24mm)
Step Resolution .....	1, 1/2, 1/4, 1/8 step
Operating Modes .....	PC controlled or standalone.
PC Control.....	Can control up to 16 drives daisy-chained together.
Communications protocol.....	RS485. Can convert to RS232/USB with appropriate converters.
Control protocol .....	Compatible with devices that use the Cavro DT or OEM protocol. Can use EZCommander™ Windows application or serial terminal program such as HyperTerminal to issue commands.
Motor compatibility.....	Accommodates most 1.5" and smaller stepper motors, including unipolar motors with center tapped winding. Best performance is with motor rated at about 1/2 of supply voltage.
Mating Connectors.....	HIROSE DF11 series. Recommended tool: Digikey H9924-ND
I/O Interface.....	Accepts 2 opto-electronic and two mechanical switch inputs, or 4 mechanical switch inputs. ADC inputs also. Signal Levels: <0.8V Vlow; >2V Vhigh (TTL compatible) Optical switch specifications: Transistor optical switch with IC > 1 mA @ IF=20mA. <i>Examples:</i> OPTEK part OPB841W55 or Digikey part 365-1103-ND (prewired); Honeywell HOA1870-33 (prewired)
Encoder interface.....	Quadrature encoder, maximum frequency 4 MHz
Operating Temperature .....	0 to 45° C standard, -20 to 50° C upon special request
Relative Humidity.....	10% to 90% non condensing (operating and storage)

## Fully intelligent Stepper Motor Controller/Driver with Encoder Feedback



Model EZ10EN actual size

### MOTOR CONNECTOR

Mating conn.: HIROSE DF11 8 pin, 24 GA, part DF11-8DS-2C  
DIGIKEY part H2022-ND

Pin	Function	Notes
1	ON/OFF driver #2 (V+)	2A peak; 1A continuous
2	ON/OFF driver #2 (V-)	Open collector
3,4	Stepper winding B	1A bipolar chopper
5,6	Stepper winding A	1A bipolar chopper
7	ON/OFF driver #1 (V+)	2A peak; 1A continuous
8	ON/OFF driver #1 (V-)	Open collector

### POWER AND CONTROL CONNECTOR

Mating conn.: HIROSE DF11 4 pin, 24 GA, part DF11-4DS-2C  
Digikey part H2019

Pin	Function
1	GROUND
2	V+ (external supply) +9V to 30V
3	RS485 A
4	RS485 B

I/O CONNECTOR		
Mating Connector: HIROSE DF11 series 8 pin, 24 GA, part DF11-8DS-2C Digikey part H2022-ND		
Pin	Name	Notes
1	A/D in #1, encoder Chan A, or Step input	Includes 6.8kΩ pullup to 5V.
2	A/D in #2, encoder Chan B, or Direct input	Includes 6.8kΩ pullup to 5V.
3	A/D in #4, encoder Index, or Upper Limit input	Includes 6.8kΩ pullup to 5V.
4	LED Drive #1 or encoder +5V power	Includes series 200Ω resistor to 5V.
5	LED Drive #12	Includes series 200Ω resistor to 5V.
6	Ground	Common ground
7	Ground	Common ground
8	A/D in #3 or Home/Lower Limit input	Includes 6.8k Ω pullup to 3.3V.

\* On smaller version it is assumed that the encoder functions will be used. Pin 6 is hard-wired to +5V.

## Mechanical Specifications

Smaller version is for mounting inside encoder.

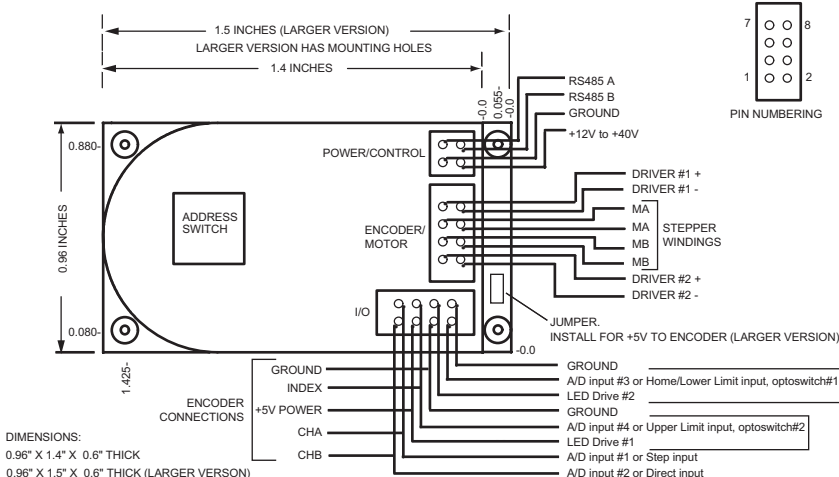

## Key Features

- Smaller than a typical quadrature encoder
- Single 4-wire bus linking up to 16 drives
- 1A chopper (PWM) stepper driver
- Operates from 9V to 30V
- RS232, RS485 or USB based control communications
- Optional standalone operation with no connection to PC
- Execution halt pending switch closure
- Prewired for optoswitch inputs
- Full, half, quarter, and eighth step bipolar control
- Cavro DT or OEM protocol compatible
- Homes to an optical or mechanical switch closure with a single command
- Fully programmable ramps and speeds
- Four digital I/O; and two 1A power On/Off drivers for driving relay, dc motors, solenoids, etc. included
- Optional ADC inputs
- Optional encoder feedback
- Switch-selectable device address
- Software-settable "Move" and "Hold" currents
- Hold current auto selected upon move completion

## Ordering Information

<b>Name</b>	<b>Order Number</b>
EZ10EN Stepper Drive.....	EZ10EN
RS232 to 485 Converter (option).....	RS485
USB to 485 Converter (option).....	USB485