

**POWER INPUT AND RS485 COMMUNICATION**

+9V TO +30V  
 GROUND  
 RS485 B  
 RS485 A

**ENCODER1**

GROUND  
 INDEX  
 CHAN A  
 +5V  
 CHAN B  
 MOTOR1 UPPER LIMIT POWER  
 MOTOR1 UPPER LIMIT IN  
 GROUND  
 MOTOR1 LOWER LIMIT POWER  
 MOTOR1 LOWER LIMIT IN  
 GROUND

**MOTOR1 LIMITS**

**USB CONNECTION**

**USB**

**DIGITAL I/O CONNECTOR**

OPTO SENSOR #1 GROUND / SW CLOSURE GND  
 OPTO SENSOR #1 PHOTO TRANSISTOR  
 OPTO SENSOR #1 LED  
 OPTO SENSOR #2 GROUND / SW CLOSURE GND  
 OPTO SENSOR #2 PHOTO TRANSISTOR  
 OPTO SENSOR #2 LED  
 SWITCH CLOSURE TO GROUND INPUT  
 SWITCH CLOSURE TO GROUND INPUT

**POWER OUTPUT DRIVERS**

1 AMP ON/OFF DRIVER #1 +  
 1 AMP ON/OFF DRIVER #1 -  
 1 AMP ON/OFF DRIVER #2 +  
 1 AMP ON/OFF DRIVER #2 -

**ADDRESS SWITCH**

**STATUS LED**

MOTOR2 UPR LIM PWR  
 MOTOR2 UPPER LIM IN  
 GROUND  
 MOTOR2 LWR LIM PWR  
 MOTOR2 LOWER LIM IN  
 GROUND

**MOTOR2 LIMITS**

MOTOR3 UPR LIM PWR  
 MOTOR3 UPPER LIM IN  
 GROUND  
 MOTOR3 LWR LIM PWR  
 MOTOR3 LOWER LIM IN  
 GROUND

**MOTOR3 LIMITS**

**LIFE LED**

MOTOR1 A+  
 MOTOR1 A- **MOTOR 1**  
 MOTOR1 B+  
 MOTOR1 B-  
 MOTOR2 A+  
 MOTOR2 A- **MOTOR 2**  
 MOTOR2 B+  
 MOTOR2 B-  
 MOTOR3 A+  
 MOTOR3 A- **MOTOR 3**  
 MOTOR3 B+  
 MOTOR3 B-  
 MOTOR4 A+  
 MOTOR4 A- **MOTOR 4**  
 MOTOR4 B+  
 MOTOR4 B-

**DO NOT UNPLUG LOADS WHILE POWER IS ON**

**DO NOT UNPLUG LOADS WHILE POWER IS ON**

**ENCODER2**

CHAN B  
 +5V  
 CHAN A  
 INDEX  
 GROUND  
 GROUND  
 MOTOR4 LOWER LIMIT IN  
 MOTOR4 LOWER LIMIT POWER  
 GROUND  
 MOTOR4 UPPER LIMIT IN  
 MOTOR4 UPPER LIMIT POWER

**MOTOR4 LIMITS**

↓ **PAGE DOWN** ↓

**COPYRIGHT ALLMOTION.COM**  
**EZ 4AXIS DRIVER CONTROLLER**

Title ALLMOTION.COM EZ STEPPER WIRING DIAGRAM		
Size B	Document Number	Rev A3
Date: Thursday, May 09, 2013	Sheet 1	of 5

TO PC COM PORT  
USE 9600 BAUD  
8BIT, NO PARITY,  
1 STOP, NO FLOW  
CTRL.

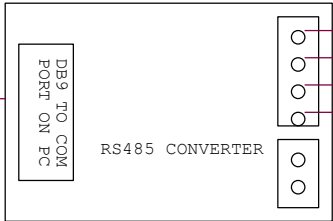

TO OTHER  
EZ STEPPERS

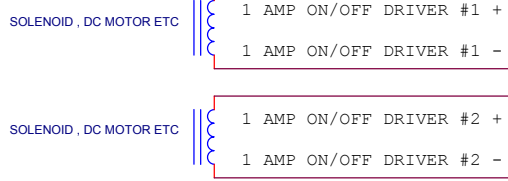
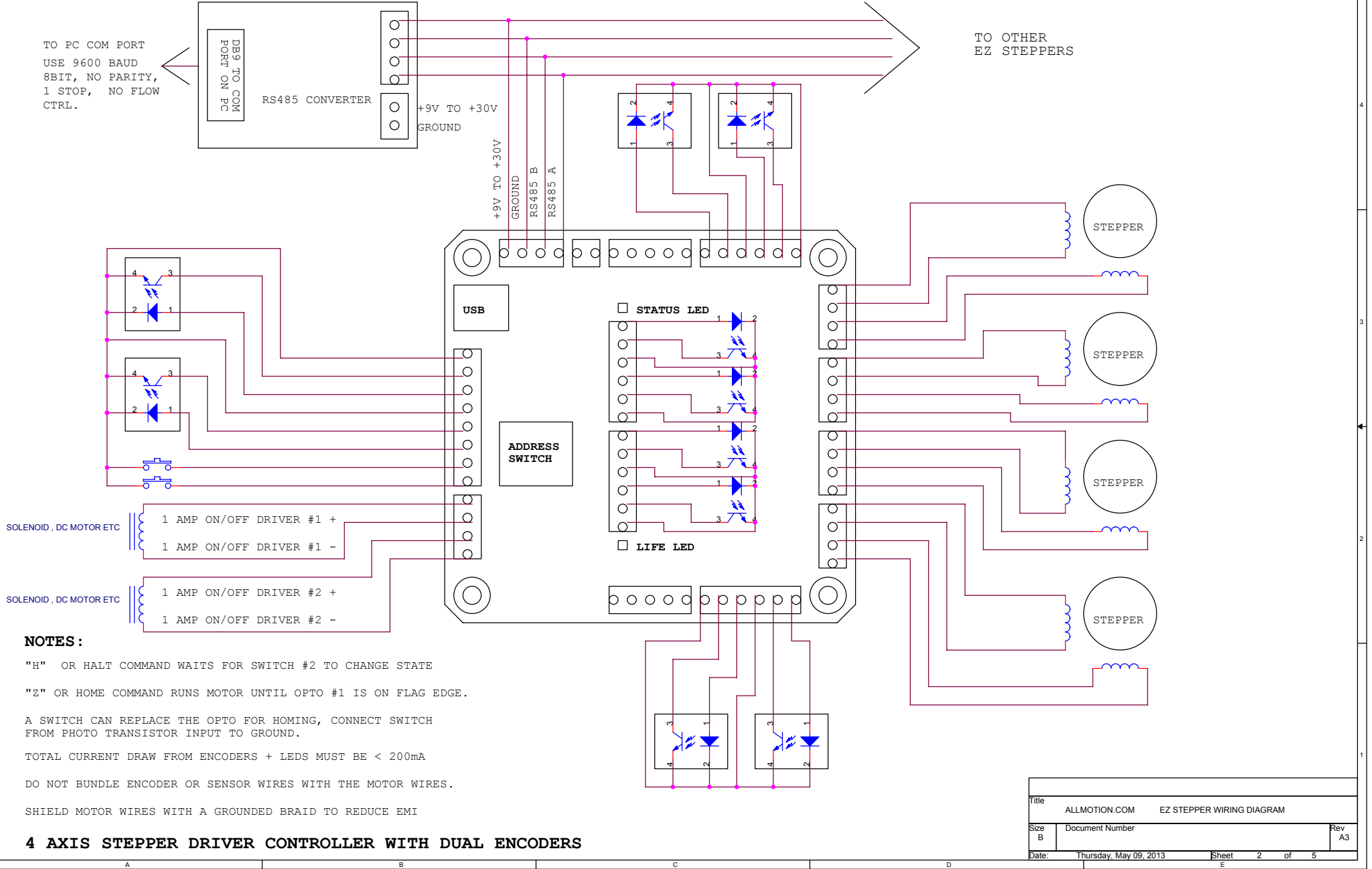

- NOTES :**
- "H" OR HALT COMMAND WAITS FOR SWITCH #2 TO CHANGE STATE
  - "Z" OR HOME COMMAND RUNS MOTOR UNTIL OPTO #1 IS ON FLAG EDGE.
  - A SWITCH CAN REPLACE THE OPTO FOR HOMING, CONNECT SWITCH FROM PHOTO TRANSISTOR INPUT TO GROUND.
  - TOTAL CURRENT DRAW FROM ENCODERS + LEDES MUST BE < 200mA
  - DO NOT BUNDLE ENCODER OR SENSOR WIRES WITH THE MOTOR WIRES.
  - SHIELD MOTOR WIRES WITH A GROUNDED BRAID TO REDUCE EMI

**4 AXIS STEPPER DRIVER CONTROLLER WITH DUAL ENCODERS**

Title		
ALLMOTION.COM EZ STEPPER WIRING DIAGRAM		
Size	Document Number	Rev
B		A3
Date:	Thursday, May 09, 2013	Sheet 2 of 5

## EZ 4 AXIS DRIVER CONTROLLER ACCESSORIES AND OTHER ELECTRICAL NOTES

### MATING CONNECTORS:

AMP MTA 100 SERIES  
 4PIN 22 GA DIGIKEY P/N A31108 (INPUT / MOTOR / OUTPUT CONNECTOR)  
 8PIN 26 GA DIGIKEY P/N A31030 (FOR OPTOS)  
 6PIN 26 GA DIGIKEY P/N A31028 (FOR OPTOS)  
 5PIN 26 GA DIGIKEY P/N A31027 (FOR ENCODER)

T HANDLE CRIMP TOOL DIGIKEY P/N A9982  
 PISTOL GRIP TOOL DIGIKEY P/N A1998 + A2031

### MOTORS:

- 1) THE EZ STEPPER WILL DRIVE MOST STEPPER MOTORS
- 2) FOR BEST PERFORMANCE SELECT A MOTOR THAT IS RATED AT ABOUT 1/4 OF THE SUPPLY VOLTAGE. (Eg USE A 6V MOTOR WITH A 24V SUPPLY).
- 3) FOR (UNIPOLAR) STEPPER MOTORS WITH CENTER TAPPED WINDINGS, TYPICALLY LEAVE THE CENTER TAP UNCONNECTED, OR WIRE PER MANUFACTURERS RECOMMENDATIONS.

### SUITABLE POWER SUPPLIES:

- 1) FOR FIRST TIME USERS, TO GUARD AGAINST A POSSIBLE MISWIRE, A CURRENT LIMITED LAB SUPPLY SET TO 12V AND 0.5A IS RECOMMENDED.
- 2) A SUPPLY OF 24V AND 2A CAPABILITY IS GOOD FOR MOST PURPOSES. POSSIBLE CHOICES ARE:  
 DIGIKEY P/N 237-1296-ND  
 DIGIKEY P/N 237-1395-ND (ENCLOSED)
- 3) INPUT CURRENT IS MUCH LESS THAN MOTOR CURRENT DUE TO THE SWITCHING (PWM). IT CAN BE CALCULATED BY CONSIDERING CONSERVATION OF POWER. HOWEVER IT IS IMPORTANT TO MAKE SURE THAT THE SUPPLY WILL NOT FOLD BACK AS IT IS COMING UP SINCE THE EZ STEPPER WILL DRAW MORE CURRENT AT LOWER VOLTAGES.

### OPTO HOME SWITCH:

- 1) "Z" OR HOME COMMAND RUNS MOTOR UNTIL OPTO #1 IS ON FLAG EDGE.
- 2) AN OPTO SWITCH PROVIDED WITH EACH STARTER KIT
- 3) USE TRANSISTOR OPTO THAT HAS  $I_c > 1mA$  @  $I_F = 20mA$ .
- 4) EXAMPLES OF ACCEPTABLE OPTOS ARE:  
 DIGIKEY P/N QVA11134  
 DIGIKEY P/N H21A1  
 HONEYWELL HOA1887-012 (IS PREWIRED)  
 HONEYWELL HOA1870-33 (IS PREWIRED)  
 OPTEK OPB830W11 (IS PREWIRED)

5) THE OPTO COUPLER LED PIN HAS 150 OHM TO 5V IN SERIES ON THE BOARD. THE 150 OHM CAN BE REMOVED IF DESIRED FOR RUNNING SENSORS THAT REQUIRE DIRECT ACCESS TO 5V. THE COLLECTOR OF THE TRANSISTOR HAS A 10K PULLUP TO 5V.

6) ALL INPUTS WORK ON TTL LEVEL SIGNALS

### ON/OFF DRIVERS ALTERNATE WIRING DIAGRAM

- 1) ON/OFF DRIVERS RATED AT 2 AMPS PEAK, 1 AMP CONTINUOUS.
- 2) THE NEGATIVE PIN OF THESE DRIVERS IS ACTUALLY AN OPEN COLLECTOR TYPE OUTPUT THAT PULLS DOWN TO GROUND. IT IS POSSIBLE TO DRIVE LOADS THAT ARE OF A DIFFERENT VOLTAGE THAN THE SUPPLY VOLTAGE, BY CONNECTING THE POSITIVE SIDE OF THE LOAD TO AN EXTERNAL SUPPLY, AND THE NEGATIVE SIDE TO THE -VE OUTPUT PIN. HOWEVER, IN CASE THIS IS DONE IT IS NECESSARY TO PLACE AN EXTERNAL "FREE WHEELING" DIODE ACROSS ANY INDUCTIVE LOADS. EXTERNAL SUPPLY VOLTAGE MUST BE LESS THAN SUPPLY VOLTAGE TO EZ STEPPER
- 3) EXTERNAL DIODE IS NOT NECESSARY IF BOTH SIDES OF LOAD ARE WIRED BACK TO THE EZ STEPPER.

### ON/OFF DRIVERS ALTERNATE WIRING DIAGRAM

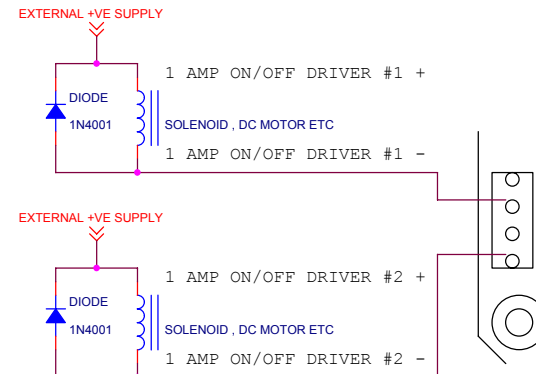

EXTERNAL SUPPLY VOLTAGE  
 MUST BE LESS THAN SUPPLY  
 TO EZ STEPPER

PAGE DOWN FOR MORE INFO

COPYRIGHT ALLMOTION.COM

Title		
ALLMOTION.COM EZ STEPPER WIRING DIAGRAM		
Size	Document Number	Rev
B		A3
Date: Thursday, May 09, 2013		Sheet 3 of 5

FEEDBACK POT1 GROUND  
 FEEDBACK POT1 WIPER  
 FEEDBACK POT1 POWER

POSITION COMMAND POT2 GROUND  
 POSITION COMMAND POT2 WIPER  
 POSITION COMMAND POT2 POWER

SWITCH #1 CLOSURE TO GROUND INPUT  
 SWITCH #2 CLOSURE TO GROUND INPUT

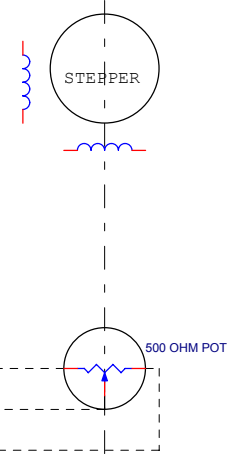
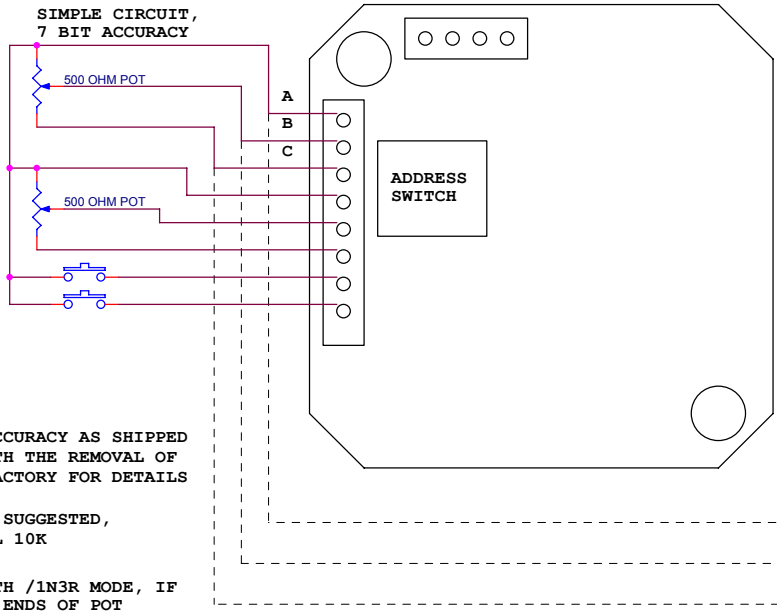

NOTES:

- 1) ALL 4 INPUTS ARE ANALOG INPUTS
- 2) ADC's VALUES RANGE FROM 0-16368. THE ACCURACY AS SHIPPED IS 7 BIT BUT CAN BE IMPROVED TO >10BIT WITH THE REMOVAL OF THE INPUT PROTECTION CIRCUITRY, CONTACT FACTORY FOR DETAILS
- 3) POTS IN THE RANGE OF 500 OHM - 10K ARE SUGGESTED, LOWER VALUES ARE LESS AFFECTED BY INTERNAL 10K PULLUP. 500 OHM RECOMMENDED.
- 4) IF USING POT FOR POSITION FEED BACK WITH /1N3R MODE, IF MOTOR EXHIBITS POSITIVE FEEDBACK, SWITCH ENDS OF POT
- 5) 10K INTERNAL PULLUP WILL INTERFERE WITH LINEARITY OF POT VOLTAGE, AND MAY NEED TO BE REMOVED - CONTACT FACTORY.
- 6) INPUT OVERVOLTAGE PROTECTION CIRCUITRY MAY NEED TO BE REMOVED FOR >7BIT ACCURACY - CONTACT FACTORY.

CIRCUITS INTERNAL TO DRIVE

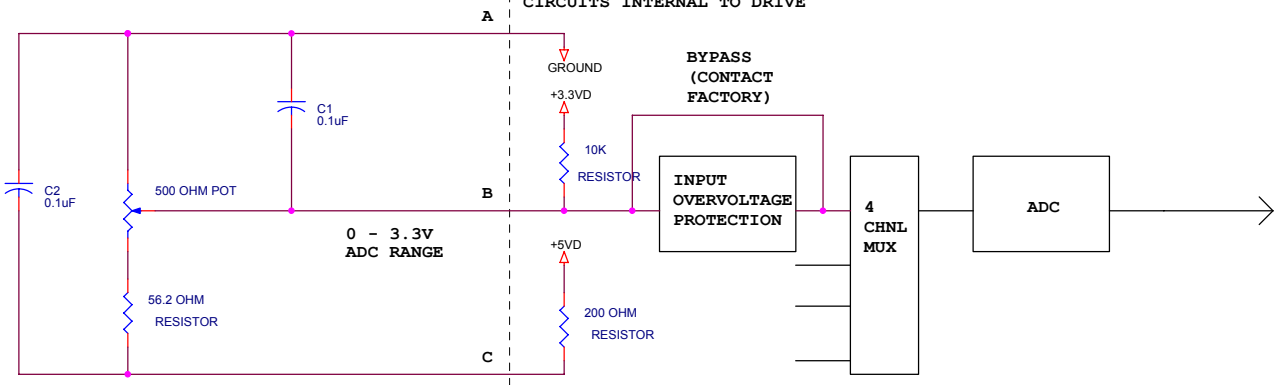

ENHANCED EXTERNAL CIRCUIT FOR > 10BIT ACCURACY

WIRING DIAGRAM ANALOG INPUT OR POTENTIOMETER FEEDBACK

Title		ALLMOTION.COM EZ STEPPER WIRING DIAGRAM	
Size	Document Number	Rev	
B		A3	
Date:	Thursday, May 09, 2013	Sheet	4 of 5

COPYRIGHT ALLMOTION.COM

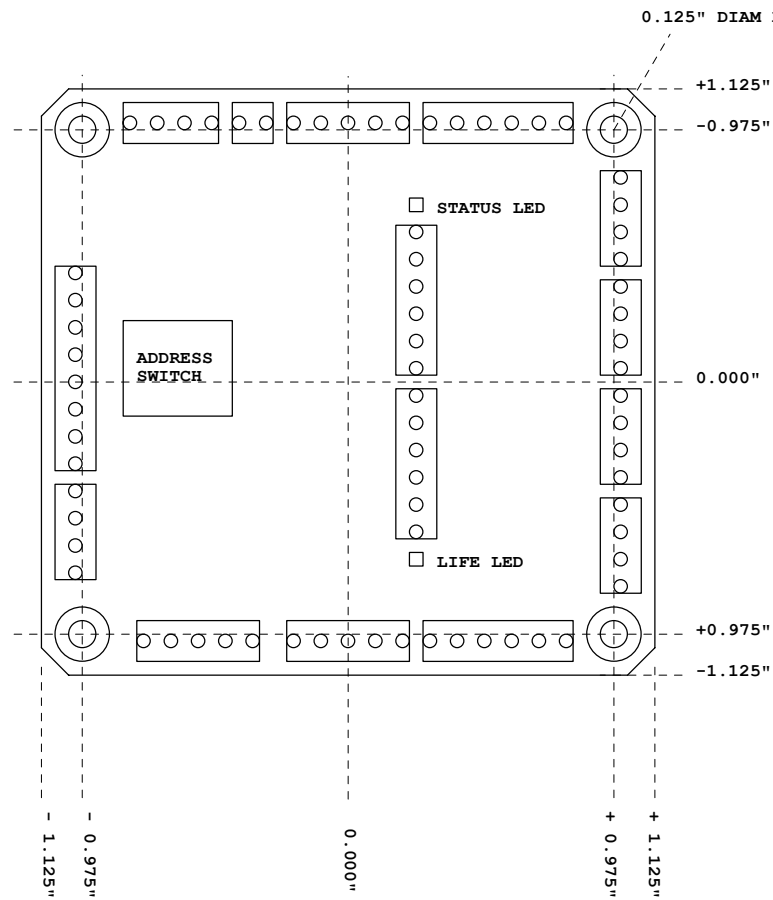

**4 AXIS CONTROLLER DRIVER DIMENSIONAL INFORMATION**      **COPYRIGHT ALLMOTION.COM**

Title		ALLMOTION.COM    DIMENSIONAL INFO	
Size	Document Number	Rev	
B		A3	
Date:	Thursday, May 09, 2013	Sheet	5 of 5