

TO PC COM PORT

USE 9600 BAUD
8BIT, NO PARITY,
1 STOP, NO FLOW
CTRL.

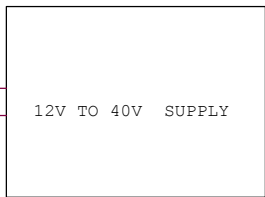
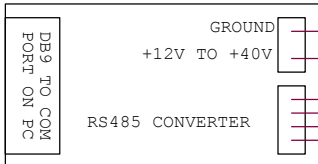

TO OTHER
EZ STEPPERS

DO NOT UNPLUG LOADS WHILE POWER IS ON

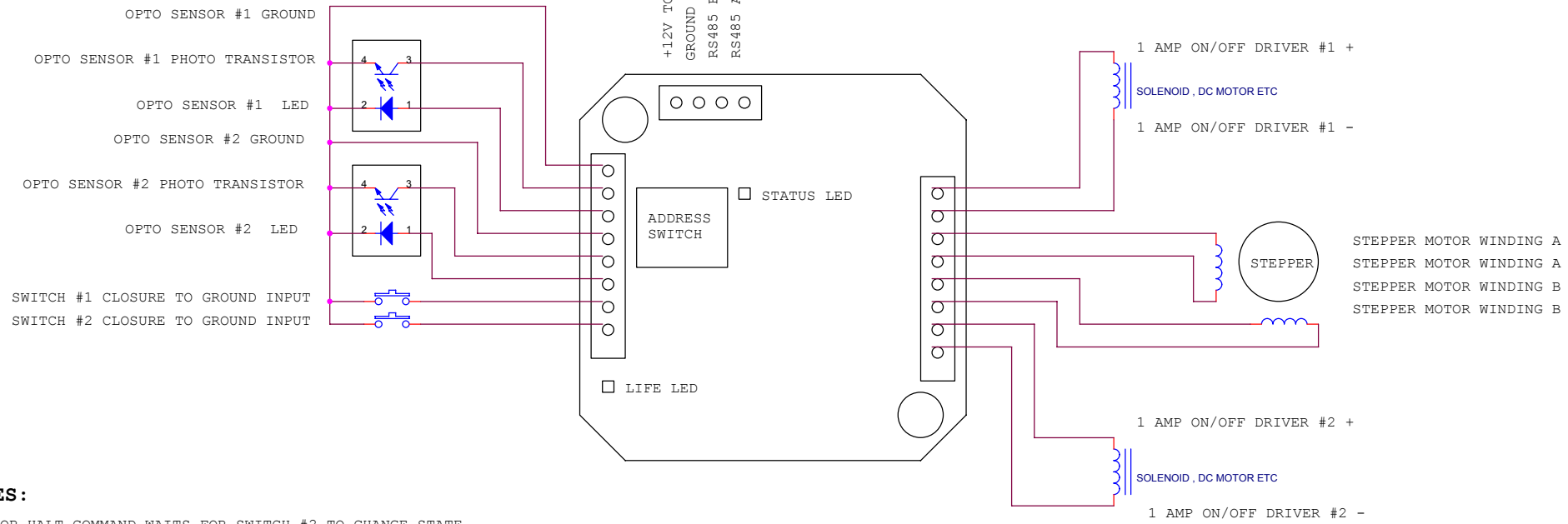

NOTES:

"H" OR HALT COMMAND WAITS FOR SWITCH #2 TO CHANGE STATE

"Z" OR HOME COMMAND RUNS MOTOR UNTIL OPTO #1 IS ON FLAG EDGE.

A SWITCH CAN REPLACE THE OPTO FOR HOMING, CONNECT SWITCH FROM PHOTO TRANSISTOR INPUT TO GROUND.

SEE PAGE 2 FOR WIRING DETAILS

SEE PAGE 3 FOR ACCESSORIES

SEE PAGE 4 FOR DIMENSIONAL INFO

EZ17 AND EZ23 WIRING DIAGRAM

Title		ALLMOTION.COM	EZ STEPPER WIRING DIAGRAM
Size	Document Number	Rev	
B	DOCUMENT_REV_A8	A11	
Date:	Thursday, December 06, 2007	Sheet	1 of 4

**4 SWITCH CLOSURE,
OR 2 OPTO AND 2
SWITCH CLOSURE
INPUTS**

DIGITAL I/O CONNECTOR

- OPTO SENSOR #1 GROUND / SW CLOSURE GND
- OPTO SENSOR #1 PHOTO TRANSISTOR
- OPTO SENSOR #1 LED
- OPTO SENSOR #2 GROUND / SW CLOSURE GND
- OPTO SENSOR #2 PHOTO TRANSISTOR
- OPTO SENSOR #2 LED
- SWITCH CLOSURE TO GROUND INPUT
- SWITCH CLOSURE TO GROUND INPUT

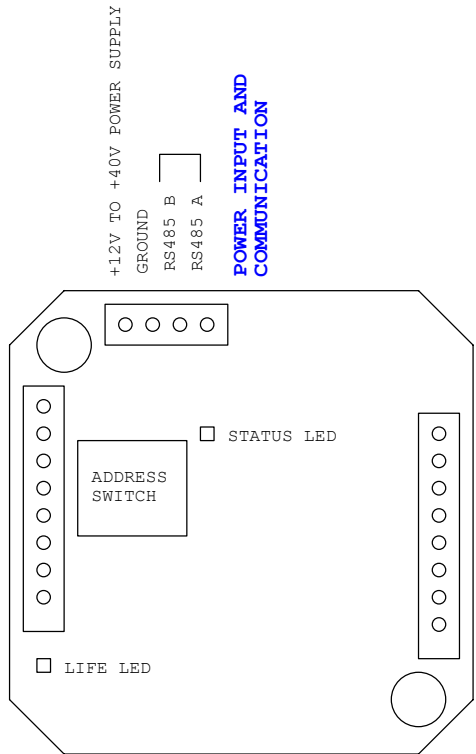

POWER OUTPUT DRIVERS

- 2 AMP ON/OFF DRIVER #1 +
- 2 AMP ON/OFF DRIVER #1 -
- STEPPER MOTOR WINDING A
- STEPPER MOTOR WINDING B
- STEPPER MOTOR WINDING B
- 2 AMP ON/OFF DRIVER #2 +
- 2 AMP ON/OFF DRIVER #2 -

**1.25 AMP PEAK BIPOLAR
STEPPER DRIVE, AND 2
AMP PEAK ON/OFF DRIVERS
FOR RELAYS, DC MOTORS,
SOLENOIDS ETC.**

EZ17 AND EZ23 WIRING DIAGRAM

Title		
ALLMOTION.COM EZ STEPPER WIRING DIAGRAM		
Size	Document Number	Rev
B	DOCUMENT_REV_A8	A11
Date: Thursday, December 06, 2007		
Sheet		2 of 4

COPYRIGHT ALLMOTION.COM

EZ17 AND EZ23 ACCESSORIES AND OTHER ELECTRICAL NOTES

MATING CONNECTORS:

AMP MTA 100 SERIES
 4PIN 22 GA DIGIKEY P/N A31108 (INPUT CONNECTOR)
 8PIN 22 GA DIGIKEY P/N A31111 (NEMA23 MOTOR)
 8PIN 24 GA DIGIKEY P/N A31023 (NEMA17 MOTOR)
 8PIN 26 GA DIGIKEY P/N A31030 (FOR OPTOS)
 5PIN 26 GA DIGIKEY P/N A31027 (FOR ENCODER)
 T HANDLE CRIMP TOOL DIGIKEY P/N A9982
 PISTOL GRIP TOOL DIGIKEY P/N A1998 + A2031

MOTORS:

- 1) THE EZ STEPPER WILL DRIVE MOST STEPPER MOTORS
- 2) FOR BEST PERFORMANCE SELECT A MOTOR THAT IS RATED AT ABOUT 1/4 OF THE SUPPLY VOLTAGE. (Eg USE A 6V MOTOR WITH A 24V SUPPLY).
- 3) FOR (UNIPOLAR) STEPPER MOTORS WITH CENTER TAPPED WINDINGS, TYPICALLY LEAVE THE CENTER TAP UNCONNECTED, OR WIRE PER MANUFACTURERS RECOMMENDATIONS.

SUITABLE POWER SUPPLIES:

- 1) FOR FIRST TIME USERS, TO GUARD AGAINST A POSSIBLE MISWIRE, A CURRENT LIMITED LAB SUPPLY SET TO 12V AND 0.5A IS RECOMMENDED.
- 2) A SUPPLY OF 24V AND 2A CAPABILITY IS GOOD FOR MOST PURPOSES. POSSIBLE CHOICES ARE:
 DIGIKEY P/N 271-1112
 DIGIKEY P/N Z1158 (ENCLOSED)
- 3) INPUT CURRENT IS MUCH LESS THAN MOTOR CURRENT DUE TO THE SWITCHING (PWM). IT CAN BE CALCULATED BY CONSIDERING CONSERVATION OF POWER. HOWEVER IT IS IMPORTANT TO MAKE SURE THAT THE SUPPLY WILL NOT FOLD BACK AS IT IS COMING UP SINCE THE EZ STEPPER WILL DRAW MORE CURRENT AT LOWER VOLTAGES.

OPTO HOME SWITCH:

- 1) "Z" OR HOME COMMAND RUNS MOTOR UNTIL OPTO #1 IS ON FLAG EDGE.
- 2) AN OPTO SWITCH PROVIDED WITH EACH STARTER KIT
- 3) USE TRANSISTOR OPTO THAT HAS $I_c > 1\text{mA}$ @ $I_F = 20\text{mA}$.
- 4) EXAMPLES OF ACCEPTABLE OPTOS ARE:
 DIGIKEY P/N QVA11134
 DIGIKEY P/N H21A1
 HONEYWELL HOA1887-012 (IS PREWIRED)
 HONEYWELL HOA1870-33 (IS PREWIRED)
 OPTEK OPB830W11 (IS PREWIRED)
- 5) THE OPTO COUPLER LED PIN HAS 150 OHM TO 5V IN SERIES ON THE BOARD. THE 150 OHM CAN BE REMOVED IF DESIRED FOR RUNNING SENSORS THAT REQUIRE DIRECT ACCESS TO 5V. THE COLLECTOR OF THE TRANSISTOR HAS A 10K PULLUP TO 5V.
- 6) ALL INPUTS WORK ON TTL LEVEL SIGNALS

ON/OFF DRIVERS ALTERNATE WIRING DIAGRAM

- 1) ON/OFF DRIVERS RATED AT 2 AMPS PEAK, 1 AMP CONTINUOUS.
- 2) THE NEGATIVE PIN OF THESE DRIVERS IS ACTUALLY AN OPEN COLLECTOR TYPE OUTPUT THAT PULLS DOWN TO GROUND. IT IS POSSIBLE TO DRIVE LOADS THAT ARE OF A DIFFERENT VOLTAGE THAN THE SUPPLY VOLTAGE, BY CONNECTING THE POSITIVE SIDE OF THE LOAD TO AN EXTERNAL SUPPLY, AND THE NEGATIVE SIDE TO THE -VE OUTPUT PIN. HOWEVER, IN CASE THIS IS DONE IT IS NECESSARY TO PLACE AN EXTERNAL "FREE WHEELING" DIODE ACROSS ANY INDUCTIVE LOADS. EXTERNAL SUPPLY VOLTAGE MUST BE LESS THAN SUPPLY VOLTAGE TO EZ STEPPER
- 3) EXTERNAL DIODE IS NOT NECESSARY IF BOTH SIDES OF LOAD ARE WIRED BACK TO THE EZ STEPPER.

ON/OFF DRIVERS ALTERNATE WIRING DIAGRAM

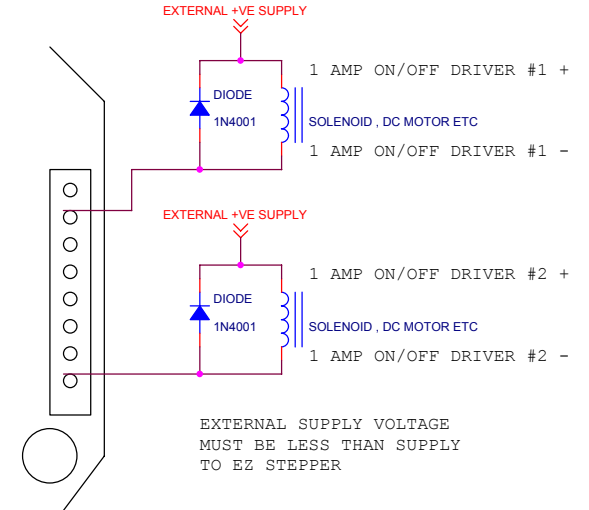

SEE NEXT PAGE FOR DIMENSIONAL INFO

COPYRIGHT ALLMOTION.COM

Title		
ALLMOTION.COM EZ STEPPER WIRING DIAGRAM		
Size	Document Number	Rev
B	DOCUMENT_REV_A8	A11
Date:	Thursday, December 06, 2007	Sheet 3 of 4

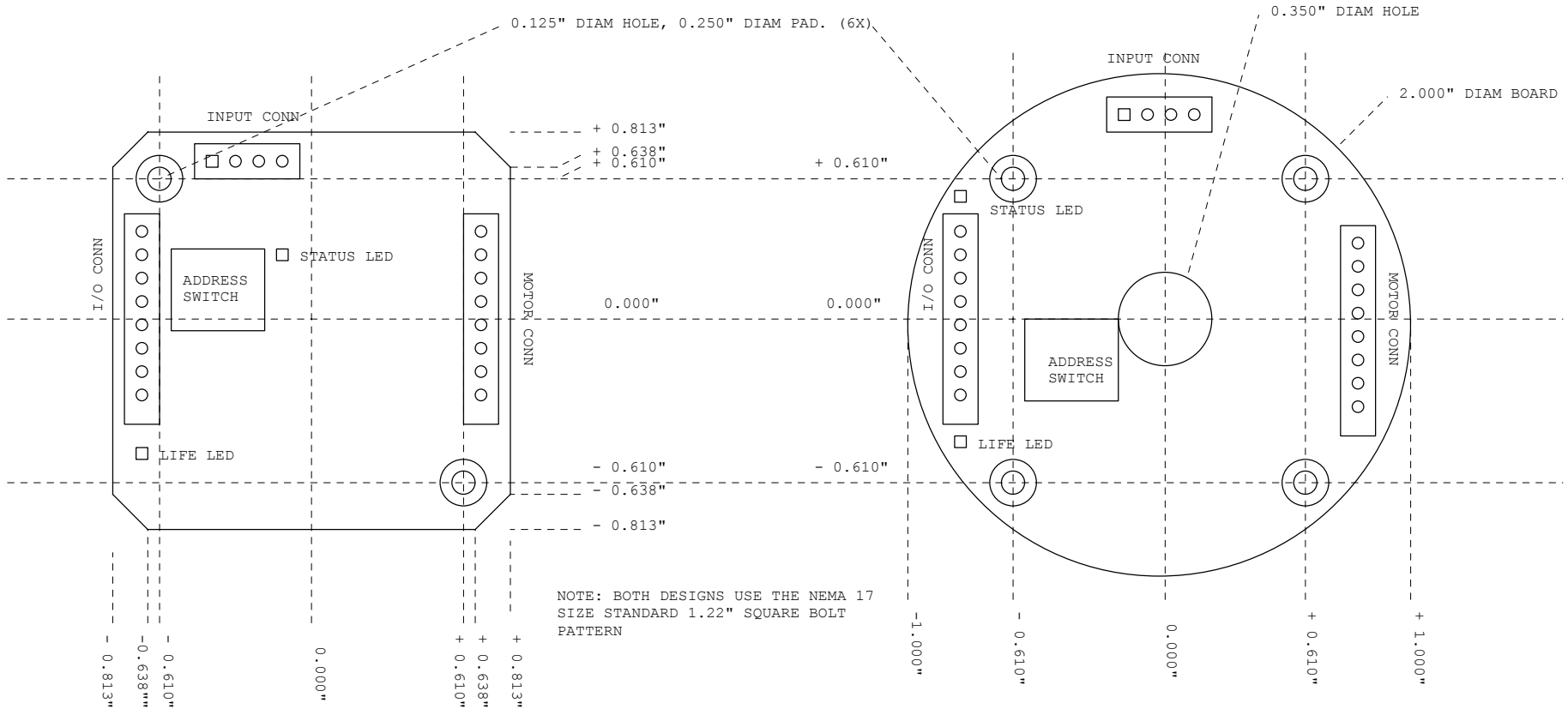

NOTE: BOTH DESIGNS USE THE NEMA 17
 SIZE STANDARD 1.22" SQUARE BOLT
 PATTERN

+ 1.000" TOP
 COMPONENTS FOR SIZE23

+ 0.562" TOP COMPONENTS
 FOR SIZE17

+0.062" PCB THICKNESS
 0.000"
 -0.125" BOTTOM COMPONENTS

EZ17 AND EZ23 DIMENSIONAL INFORMATION

COPYRIGHT ALLMOTION.COM

Title		
ALLMOTION.COM EZ STEPPER DIMENSIONAL INFO		
Size	Document Number	Rev
B	DOCUMENT_REV_A8	A11
Date:	Thursday, December 06, 2007	Sheet 4 of 4